

Gigabit Ethernet Muxponder

Effective Layer 1 aggregation of Ethernet traffic

Key benefits:

- Cost-efficient aggregation of Ethernet traffic on to a 2.5Gb/s line signal
- Protected configurations enabled by dual line ports
- Remote management and signaling through in-band management
- Technology agnostic. Pluggable transceivers enable usage in CWDM as well as DWDM networks
- Low Power Design for low Total Cost of Ownership

The Double-Dual GbE Muxponder (TPDDGBE) is a powerful part of Transmode's TM-Series platform, enabling cost-efficient transport of Ethernet traffic. The TPDDGBE is based on Transmode's Intelligent WDM (iWDM) concept where the same hardware unit can be configured for different functional behavior and thus reduces the Total Cost of Ownership (TCO) for an operator.

Optimized for Ethernet backhaul applications

The TPDDGBE is a generic traffic unit that is ideal in access and metro networks for backhaul of Ethernet traffic. It is especially suitable in ADSL/DSLAM and Triple-Play backhaul networks. The TPDDGBE has two individual 2x Ethernet aggregation functions on the same board. Each of the two functions perform TDM multiplexing of two Gigabit Ethernet (electrical or optical) or Fast Ethernet (electrical) signals onto one wavelength channel having a line rate of 2,488Gb/s.

All client interfaces use pluggable transceivers (SFPs) enabling each client connection to be adapted to type of interface (SM, MM, electrical etc) and distance to the client equipment. Each of the aggregation functions has two SFP-based line ports giving the ability to provide sub 50ms 1+1 line protection simply by inserting a second SFP and configuring the unit via the graphical user interface.

The usage of pluggable transceivers provides valuable flexibility since the TPDDGBE can be used in both CWDM and DWDM networks only by selecting the appropriate type of SFPs.

Simplified management via iWDM

Transmode's iWDM concept wraps the client signals of the TPDDGBE into a digital frame. This digital frame has overhead bytes that carry the management channels, and it also provides quality control of the transmission via performance data. The embedded management channel simplifies the management of a Transmode network since management access is provided wherever there is a traffic connection.



Reconfigurable hardware

For situations where the line signal must be regenerated to bridge longer distances, the same hardware unit can be initiated into a 4x Regenerator function.

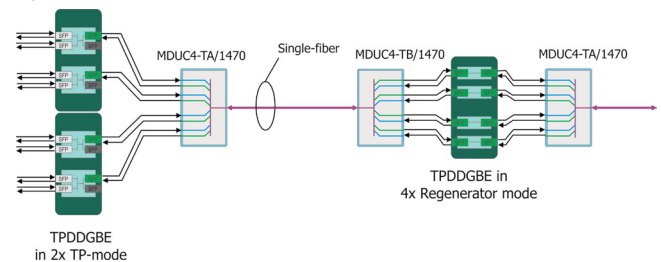

Fig 1: Cascaded network example using TPDDGBE

The regenerator function enables remote management access to the regenerator site via the embedded management channels.

Tailored Network Element options

The TPDDGBE can be mounted in any of the TM-Series chassis options;

- As a self-managed Network Element in a 1U TM-101/102 chassis
- As one of many traffic units in a TM-3000 (10U) or TM-301 (3U) chassis

This enables a tailored setup depending on current and future capacity needs of the site.

In the TM-101/102 option, the TPDDGBE initiates the complete Embedded Node Management (ENM) on the on-board micro processor. This enables local management simply by connecting any PC or work station and launching a standard internet browser.

The embedded management channels enable easy remote management via the line signal. There is thus no need to provide access to the customer DCN network if the GbE Muxponder is placed at a customer site.

Networking examples prove flexibility

To show the flexibility of the TPDDGBE a couple of networking examples are shown below.

DSLAM Collector networks

The TPDDGBE is ideal for IP/DSLAM collector networks where GbE-signals are collected and transported up to a hub site. The figure shows how a collector node can be realized using a TPDDGBE mounted in the 1U TM-102 chassis together with an east-west CWDM AD-filter. This configuration provides 4x GbE-pipes towards the hub node. Protection can be applied in the DSLAM layer via Layer 2 mechanisms, or the 1+1 Line protection function can be applied towards the hub.

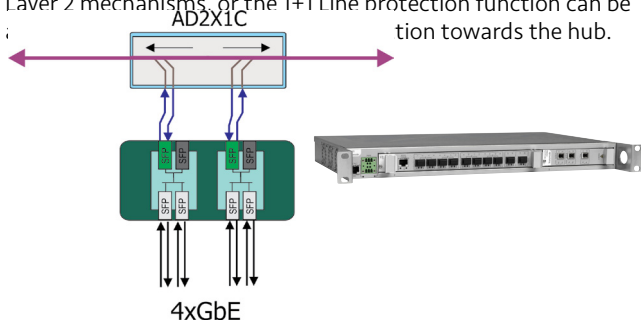

Fig 2: TPDDGBE is ideal in IP/DSLAM collector networks

Broadcast network

The TPDDGBE can also be configured for IP broadcast. A special broadcast mode is available that enables 2x GbE-signals to be broadcasted out to the satellite nodes in a ring protection configuration. The protection mechanism provides protection against fiber cuts and node failures. Furthermore, it enables additional satellite nodes to be inserted in a live network.

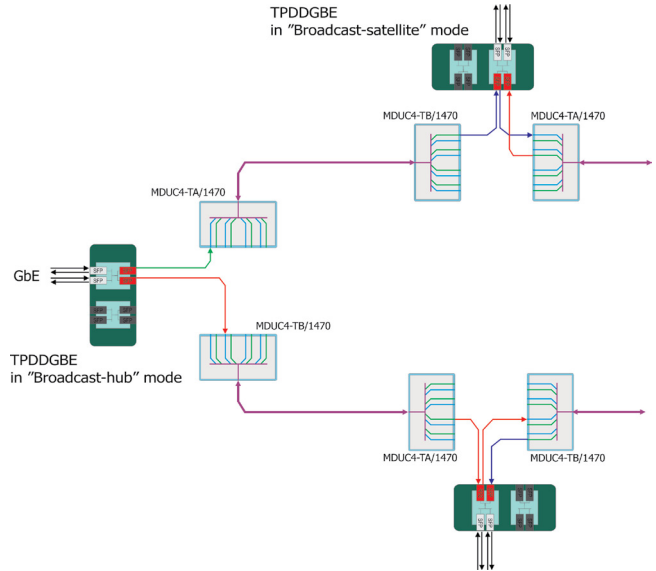

Fig 3: Showing a part of a Broadcast network

The second half of the TPDDGBE can be used for e.g. bi-directional traffic.

Low Power Design

A fully equipped TPDDGBE consumes less than 26W. Low power consumption in combination with a small footprint reduces site costs and enables more capacity to be handled at sites with restrictions on power consumption, cooling and space.

Technical specifications

Supported traffic formats	Gigabit Ethernet (electrical and optical) Fast Ethernet (electrical)
Layer 1 Performance Monitoring	Gigabit Ethernet: Based on CRC and 8B10B coding errors Line signal: Based on CRC Collected every 15min/24h and presented according to G.826 using ES, SES etc
Protection	1+1 Line protection. Non-revertive switching in normal mode , typically <20ms Revertive switching in Broadcast mode.
Power consumption	Max 26W worst case (with all client ports active and using DWDM SPFs)
Misc line interface features	Embedded management channels on line signals Trail Trace insertion to validate connection
Interfaces	Client interfaces: SFP-based. Supporting MM, SM @ 1310nm/1550nm, electrical SFPs etc Line interfaces: SFP-based. 40ch DWDM, 8ch CWDM
Layer 2 features	GbE utilization PM (in %) per GbE port
Latency	3us end-to- end between two TPDDGBE units

The specifications and information within this document are subject to change without further notice. All statements, information and recommendations are believed to be accurate but are presented without warranty of any kind. Contact Transmode for more details.